

SIG-FEED



For high-speed, continuous feeding that reduces manual loading and improves production efficiency.



CONTINUOUS PREFEEDING PERFORMANCE

The SIG-FEED Prefeeder delivers a steady supply of blanks to the folder gluer to support uninterrupted production.



ADVANTAGES

- ▶ **Continuous Feeding Operation** – Supports high-speed, uninterrupted feeding of blanks into the folder gluer.
- ▶ **Reduced Manual Loading** – Ergonomic design simplifies blank loading and helps reduce operator fatigue.
- ▶ **Precise Blank Feeding** – Provides accurate feed control for folding carton.
- ▶ **Flexible Blank Size Adjustment** – Fully adjustable feed gates accommodate a wide range of blank sizes.
- ▶ **Speed Control Adjustment** – AC variable speed drive allows operators to match prefeeder speed to production requirements.
- ▶ **Broad Compatibility** – Roll-up design offers increased productivity, seamlessly integrating with most folder gluer brands.

APPLICATIONS

- ▶ High-speed production environments needing consistent blank feeding
- ▶ Converters seeking to reduce manual blank loading
- ▶ Production lines aiming to improve feeding consistency
- ▶ Increase folder gluer productivity with prefeeder automation

THE SIGNATURE DIFFERENCE

Every Signature Folder Gluer is built for long-term performance and crafted with the operator in mind. From durable construction to intuitive design, each model delivers exceptional ease of use and dependable accuracy. With versatile configurations and custom options tailored to your production needs, Signature machines are engineered to grow with your business – delivering reliability, precision, and flexibility run after run.

MACHINE SPECIFICATIONS

Model	70	90	110
Production Speed	up to 550 m/min	up to 550 m/min	up to 550 m/min
Length/Width (M)	2.32 / 1.21	2.32 / 1.36	2.32 / 1.56
Air Connection	min. 5 bar	min. 5 bar	min. 5 bar
Air Consumption	max. 70 NL/min	max. 70 NL/min	max. 70 NL/min

CONFIGURATION

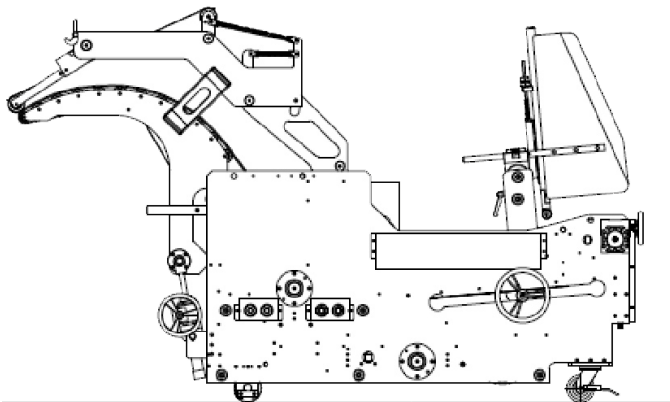

SUPPORTED CARTON STYLES

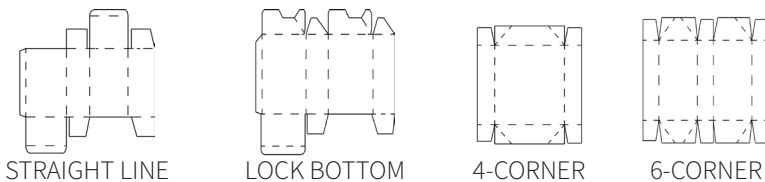

Optional heavy duty feed gate design
(for robotic loaders or heavy blank stock)

AVAILABLE SIZES

70 / 90 / 110 / 135



PAIR YOUR SIG-FEED WITH

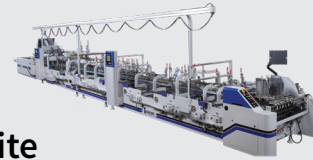

Elite

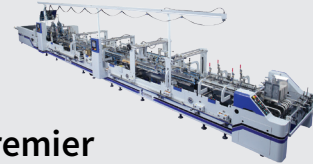

Premier



Access

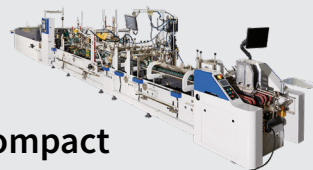

Compact

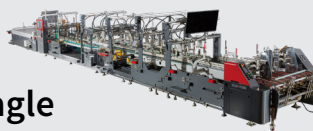

Eagle

FOLDING BOX BOARD
(200-800 gsm²)



Scan QR code
for carton specs.