

SIG-PACK Basic Preventative Maintenance Record

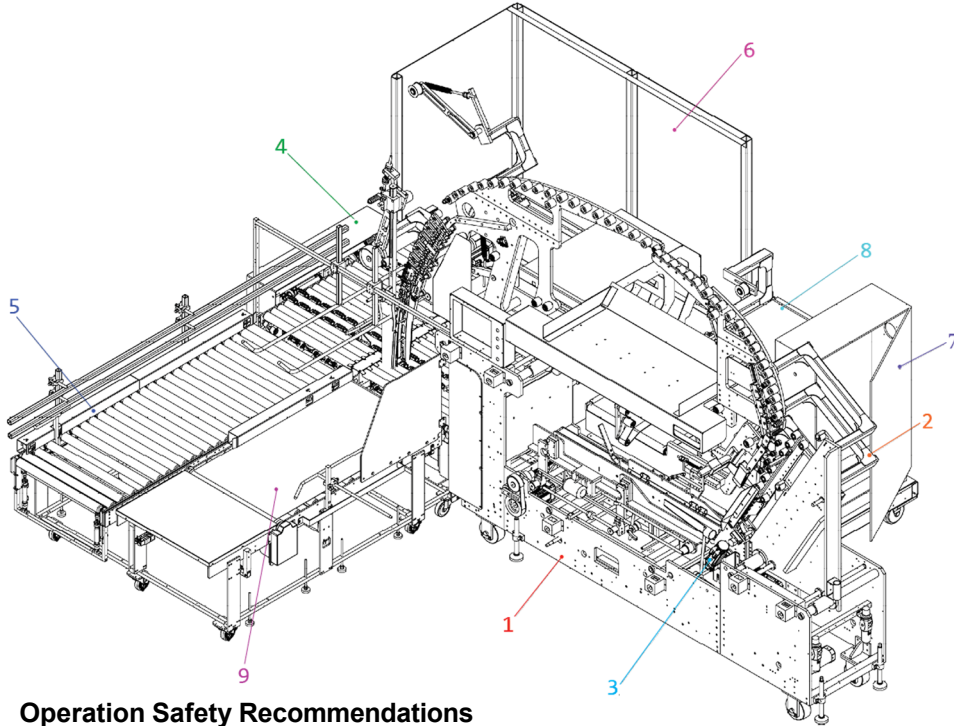

Operation Safety Recommendations

- ✓ Check all emergency [STOP] buttons daily.
- ✓ Keep fingers away from all carrier belts.
- ✓ Be cautious around all pinch point areas.
- ✓ Check that all jam detection switches are functional at least once a week.
- ✓ Always keep safety guards on machine during set up and production.
- ✓ Replace severely worn or damaged carrier belts before operating the machine.
- ✓ Keep all warning and caution signage on the machine, in place and readable.
- ✓ Proper training and tools are required for safe operation and repair attempts.
- ✓ Always wear clothing and hair styles that fit close to the body (within compliance with company dress codes) to avoid contact with the machine and potential injury.

For parts and service contact:



American International Machinery, Inc.
7725 South 6th Street | Oak Creek, WI 53154 | ph: 414.764.3223 | parts@americanintl.com | www.aim-inc.net

- Verify all guards are in place before operating the machine.
- Replace all broken handles, hoses, and electrical cables **IMMEDIATELY**.

Schedule Daily	Inspector	Inspection Date
Blow off areas 1-9, per diagram.		
Wipe down large case apron (#9).		
Schedule Weekly	Inspector	Inspection Date
Wipe down rollers and straight shafts in areas 1-9 to remove paper dust.		
Wipe down straight shafts in areas 1-3.		
Schedule Monthly	Inspector	Inspection Date
Check all belts for tension and wear.		
Check inlet belts in area 3 for wear and change as needed.		
Schedule Quarterly	Inspector	Inspection Date
Clean and oil all chains in area 5.		
Check shooter arm drive belt in area 4 for wear and tension.		
Change top and bottom shooter arm belts.		