

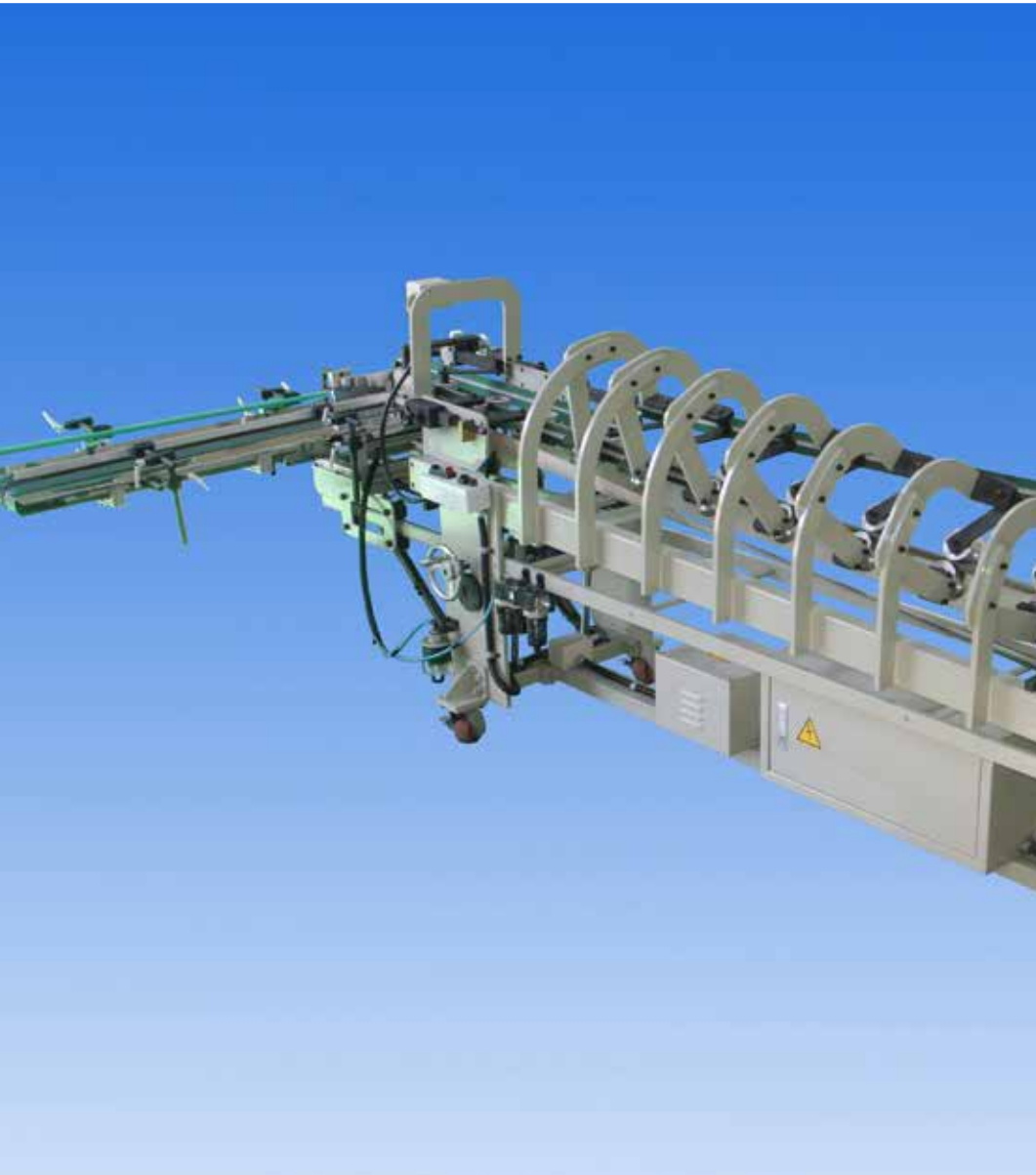

Durability, Versatility, Affordability



SPEED-O-LINE



Semi-Auto Packer for Your Folder Gluer

FEATURES

- Castor mounted for easy maneuverability
- Independent electric drive for use on any model of folder gluer
- Folder gluer feeder can be controlled from collection table
- Enables all standard folding boxes of solid board and E-flute to be produced including 4&6 corner and 4 corner with lid

TECHNICAL SPECIFICATIONS

- Min. Carton Size: 4"L x 1.75"W (100mm x 45mm)
- Max. Carton Size: 19.5"L x 16.5"W (500mm x 420mm)
- Overall Length: 12 feet
- Overall Weight: 2,640 pounds

SIGNATURE SPEED-O-LINE

Signature offers a unique line-up of ancillary converting equipment that delivers quality construction and updated technology with the added convenience of pairing with your existing equipment.

Spiral Conveyor for Easy Packing

The Signature Folder Gluer Speed-O-Line semi-automatic packer enables all standard folding cartons of solid board and E-flute to move through the spiral conveyor for easy packing by the operator.

The Speed-O-Line maneuvers easily and with its independent electric drive, can be used on any model folder gluer.



MACHINE SPECIFICATIONS

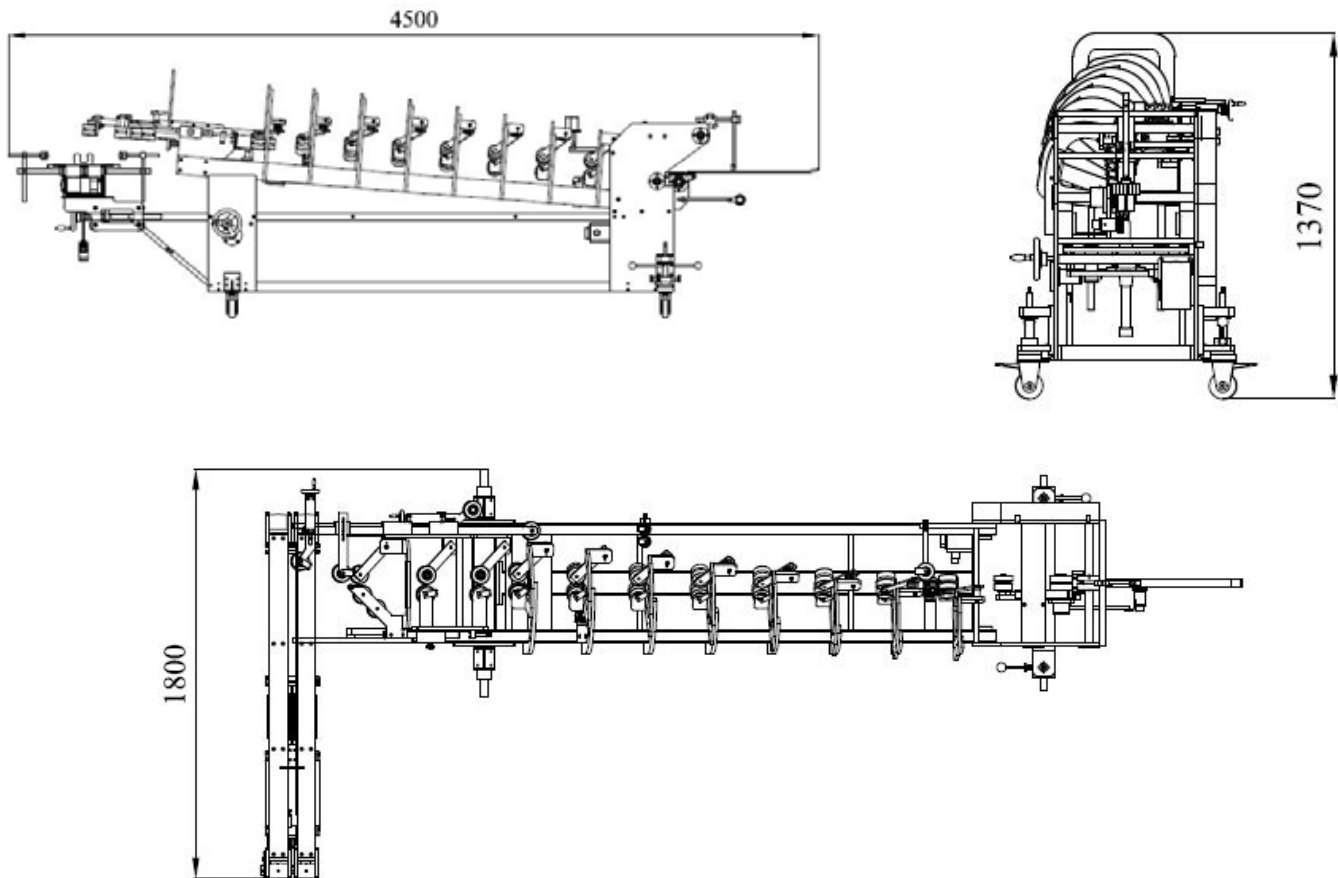

AIM USA

7725 South 6th Street
Oak Creek, WI 53154
414.764.3223 | 414.764.8679 fax
sales@americanintl.com
www.signaturefoldergluers.com

AIM Mexico

Oficina en Querétaro, México
+52 1 442 595 3439 (Inglés)
+52 1 442 467 1334 (Español)
sales@americanintl.com
www.signaturefoldergluers.com