



Durability, Versatility, Affordability



ALBATROSS



SIGNATURE ALBATROSS

The Signature brand of converting equipment is designed to meet the growing needs of today's corrugated converters through innovative design, quality construction and aggressive return on investment.

The Signature Albatross corrugated folder gluer is designed to convert large format straightline, lockbottom, and 4/6 corner products made of heavy solid board (32-60 point or 800-2000 gm²), corrugated board (N to A flute plus various double wall combinations) and folding carton material (up to 35 mm). The Albatross is capable of run speeds up to 350 m/min and inching speeds up to 20 m/min.

FEATURES



WIDER FEED BELTS

for additional control of oversized blanks moving into the alignment section.



EXTENDED ALIGNMENT SECTION

to receive and control up to 3,000 mm width blanks free and clear of overlapping in adjoining sections.



AUTO MAKE READY DEVICE

Saves carrier location settings for future retrieval. Available for the feeder, glue and final fold sections.

MACHINE SPECIFICATIONS

Standard Length: 22,700 m

Standard Weight: 32,000 kg

Total Connected Load: 60 KVA

CARTON SPECIFICATIONS

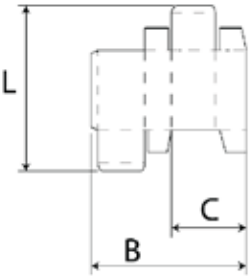
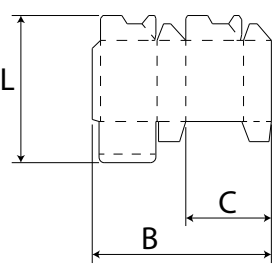
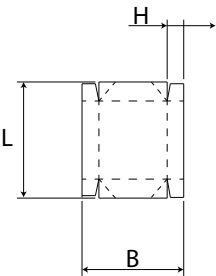
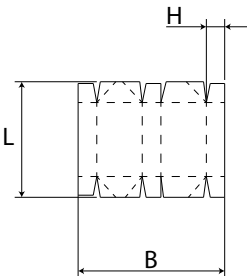
| STRAIGHTLINE | LOCKBOTTOM | 4-CORNER | 6-CORNER |
|---|---|--|---|
|  |  |  |  |
| B = 290-3000 mm | B = 290-3000 mm | B = 290-3000 mm | B = 500-3000 mm |
| L = 190-1600 mm | L = 190-1600 mm | L = 190-1600 mm | L = 220-1000 mm |
| C = 140-1450 mm | C = 140-1450 mm | C = 40-270 mm | C = 40-270 mm |



AIM USA

7725 South 6th Street
Oak Creek, WI 53154
414.764.3223 | 414.764.8679 fax
sales@americanintl.com
www.signaturefoldergluers.com

AIM Mexico

Oficina en Querétaro, México
+52 1 442 595 3439 (Inglés)
+52 1 442 467 1334 (Español)
sales@americanintl.com
www.signaturefoldergluers.com